

Files list

Serial No. NWHS242833

Work order NW0106249901

No.	File Name	Shares	Pages	Remark
1	CE	1	2	
2	Certificate of product	1	2	
3	Certificate of hook	1	1	
4	Certificate of wire rope	1	1	
5	User manual	1	33	
6	Wiring diagram	1	8	
7				
8				
9				
10				
11				
12				
13				
14				
15				
16				
17				
18				
19				
20				
21				
22				

Compile:

Date:

Inspector:

Date:

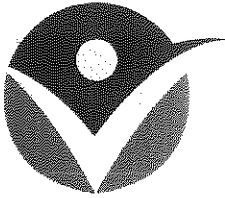

CERTING Srl

CERTIFICATE OF ADEQUACY

N°: MAC-CN0028-41-2023_rev02

Directive 2006/42/EC

Machinery NOT included in Annex IV of the Directive 2006/42/EC

Novocrane (Suzhou) Co., Ltd.

Applicant

No.1288 Pangjin Road, Wujiang Economic Development Zone, Jiangsu, China

Address

Novocrane (Suzhou) Co., Ltd.

Manufacturer

No.1288 Pangjin Road, Wujiang Economic Development Zone, Jiangsu, China

Address

ELECTRIC WIRE ROPE HOIST

Denomination

NWH Series

(series production)

Type

Serial Number

0028-35-2023

Technical file reference

EN ISO 12100: 2010

Safety of machinery - General principles for design - Risk assessment and risk reduction

EN 14492-2:2006+A1:2009/AC:2010

Cranes - Power driven winches and hoists - Part 2: Power driven hoists

EN 60204-32:2008

Safety of machinery. Electrical equipment of machines Requirements for hoisting machines

Reference applicable standards

CERTING Srl - with seat in Via Genazzano, 45 - 00038 - Valmontone (RM) - ITALY - declares that the examined sample of the machinery in object - subjected to examination on a **voluntary basis** - addresses to the **ESSENTIAL HEALTH AND SAFETY REQUIREMENT**, defined in Annex I of the above mentioned Directive.

2023/11/13

Date of issue

2028/11/12

Date of expiry

The Legal Representative



CERTING Srl -

Piazza Antonio Mancini, 4 - 00196 Roma (RM) - Italia - Tel. +39 06 84242838 - Fax +39 06 87765044 - Email info@certing.org - P. Iva 16198651006

The CE mark shown on the right can only be used under the responsibility of the manufacturer - once the technical file is successfully prepared - with the completion of EC Declaration of Conformity for all the relevant Directives.

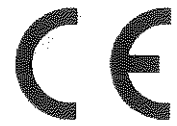

This certificate refers to the sample submitted to conformity evaluation, the procedure for assessment of conformity with internal checks on machinery production is under the responsibility of the manufacturer.

In the event that significant changes are made to the machine or to the production process the validity of this certificate will lapse. The same in the event of applicable directives significant changes.





CERTIFICATE FOR PRODUCT

Description	Electric Wire Rope Hoist	Type test Certificate No		
Code	NWH510041P75FSCN	Model&Size	NWH10t12m	
Serial No.	NWHS242833	S.W.L	10000	Kg
Height of lift	12m	Wire rope Diameter	11mm	
Lay	L	Length	54m	
Rating	M5	Insul./Prot.Class	F/IP55	
Hoisting Motor Power	9.5/1.5kW(50Hz)	Travelling Motor Power	0.96kW(87Hz)	
Hoisting speed	5/0.8m/min	Travelling Speed	5-20 m/min (variable)	
Volt. & Freq	380V/50Hz	control voltage	48V	
Overload device	NWMTC-3	Adjusted load	10500	Kg
Wiring diagram	Number of starts 30 Test run with 100% load. Dynamic overload test ,125% load. 10%under voltagetest,100% load Overload set at 110% load.			

Date

2024.06



Declaration of conformity

Herewith we:

declare that the electric wire rope hoist

specification and type

NWH510041P75FSCN

Manufacturing Code

NWHS242833

This product has been inspected and tested, founded to be in compliance with the relativity standards and codes, the drawings.

Date

2024.06

YOUNGWIRE

Factory : 193, Gongdan-ro, Seongsan-gu, Changwon-si,
Gyeongsangnam-do, Korea
Tel. +82-55-239-5500
Fax. +82-55-282-2676

Office : 7F CJ Korea Express Building 119,
Daeyo-ro, Jung-gu, Busan, Korea
Tel. +82-51-465-1946
Fax. +82-51-465-1050

CERTIFICATE OF INSPECTION (MILL TEST CERTIFICATE)

We hereby guarantee that the laboratory tests and inspection results
of steel wire rope conformed to the specification as per contract :

Customer	Rexon Drive	Date	2024/03/28
Reel No./Coil No.	21 - 26	P.O.No.	2311626
Sampling No.	21	Inv.No.	2311626-01

1. TYPE & GRADE

Diameter	11.00 mm	Construction	DURAPLUS 8SP
Grade	2160	Lubrication	A-2/A-2
Finish	DRAWN-G	Lay	LHRL
Length	1000 M	Specification	EN 12385-4

2. TEST RESULT

A. Rope

Nominal Diameter of Rope	:	11.0000	mm
Actual Diameter of Rope	:	11.2200	mm
Actual Lay Length of Rope	:	72.9000	mm
Specified Breaking Load	:	123.0	KN
Actual Breaking Load	:	127.3	KN
Preforming Test	:	GOOD	

B. Wires

Tensile Strength Test	:	SATISFACTORY	
Torsion	:	SATISFACTORY	
Weight of Zinc Coating	:	SATISFACTORY	
Wrapping & Unwrapping Test	:	SATISFACTORY	
Uniformity of Coating	:	-	

CHEMICAL ANALYSIS OF WIRE ROD

Charge No.					
	C	Si	Mn	P	S
SA67473	0.823	0.236	0.634	0.011	0.007

Remarks Inspection Certificate according to EN 10204:2004 Type 3.1, RCN 04

Factor of Safety : 24.6KN, Breaking Coefficient : 86.1KN



Chung Geun Rim

Quality Assurance Manager

wire rope electrical hoist

**Installation, Operation and Service
Manual**

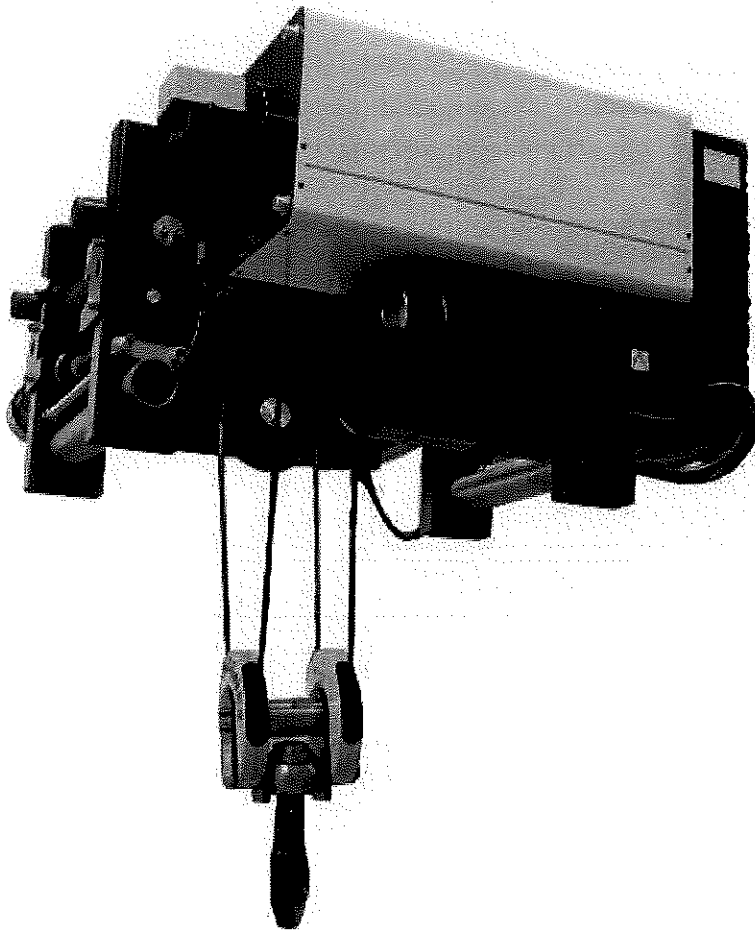

1 General description

1.1 Manual use guide

Relevant personnel should carefully read this installation, operation and service manual before commissioning electric wire rope hoist. This manual should be put on the place where the operator can read any time. Electric hoist is a tool for lifting and transporting load, there will be many potential dangers in operation process. Thus the operator need carefully read content in chapter 2 safety standards and chapter 6 tests and maintenance. This manual also including danger reminds warning and safety recommendations, and using the following words and signs to indicate:

Notice

Will cause harm to human body.

Do not conform to the manual requirements.

May cause danger to themselves or others.

Suggest reasonable and effective use of wire rope hoist.

1.2 Rational utilization

electric wire rope hoist is used for vertical lifting and horizontal load of logistics equipment, safe working load (SWL) are clearly labeled in the maintenance schedule and nameplate of equipment. At the same time in the process of operation, it must be strictly conform to the FEM working group, safe working time and start times.

wire rope hoist can be installed on the fixed structure, also can be run on the suitable rail. All design of structural components which bearing wire rope hoist should be in accordance with the corresponding specification and must in full consideration of working environment and hoist itself weight. Design and manufacture of hoist is based on indoor condition without any corrosive medium environment, its operating temperature range from - 10 °C to + 40 °C. Higher temperature will reduce hoist safety working life. The equipment will not be able to work when environment temperature is more than + 80 °C. Operating in the abnormal operating conditions or working conditions must obtain manufacturer's permission first.

Abnormal operation are including but not limited to the following condition:

- SWL load exceed safe working load

-
- Obliquely pull when on load.
 - Lifting or transport personnel
 - Start frequently
 - Wire rope intertwined
 - Wire rope bump, broken stocks, or other damage
 - Reverse operation directly
 - Deliberately operation to trigger the emergency switch operation refer to chapter 2.2 Safety operation manual)

1.3 Operation specification

Design, manufacture and operation of electric wire rope hoist is carried out with reference to the current European and German standard, and not lower than the requirements of ISO international standard. In the process of operation, users must be strictly referred to the related parameters indicated in the table. (Chapter 9.1)

1.4 Quality guarantee

Due to unreasonable use or untrained operators' improper operation, cause damage on crane, hoist or other equipment, does not undertake quality assurance and compensatory obligations. We only assume corresponding obligations to direct users and accept their quality claim meantime.

Notice

Complete adjust before operation

1. The lifting height limiter bottom switch, according to the adjustment of installation site (recommended at the place about 500 mm from the ground), it is strictly prohibited that the hook touch the ground or platform. It is forbidden that the hook operation beyond lifting height.
2. Lifting weight limiter: please check calibrate again when crane acceptance.
3. If the user replace, dismantle any parts or do not use original accessories, without permission or not in accordance with the requirements of this manual, the quality guarantee will not apply any more. For security, please use the original accessories, and according to the requirements of the user manual for wire rope hoist for maintenance and maintenance, only in this way can ensure the

product service life.

1.5 Other related information

Product quality certificate should be attached to the maintenance plan.(Chapter 9.2)

Production date should be marked on the product nameplate.

To ensure safe and effective use of wire rope hoist, we suggest that hoist installation, operation and service work should be carry by well trained professionals.

Study and remember the safety rules and regulations

Installation, operation and service manual should be reserved by personnel.

2 Safety Specification

2.1 General description

Operation, service and maintenance personnel must be carefully read and be familiar with this manual contents before work starting.

Users have the duty to take certain measures to ensure the safety of working environment,including but not limited to:

- Release the contents of the operation manual.
- Undertake the necessary testing before first use or after the big maintenance.
- Regularly testing
- Maintenance & testing result should record in maintenance list.

2.2Safety operation manual

Notice

User should ensure that the operating and maintenance personnel strictly implement the relevant provisions of the ministry of labor and security in the work process, the following information is very important to ensure the safety of the hoist and its operation and maintenance personnel.

1The user must confirm the electric hoist and its bearing structure have professional inspection and testing before the first trial run and after the major repair.

2 The user must confirm the electric hoist and its bearing structure have professional inspection and testing at least once a year.Users also need have professional inspection and testing on electric hoist according to usage and company internal requirements.

-
- 3 In the process of regular inspection and testing, users must pay attention to calculation of wire rope hoist's theoretical safe use time.
 - 4 Users must save all result and record about wire rope hoist inspection and testing.
 - 5 Wire rope hoist test results must be recorded on the wire rope hoist annual inspection record.
 - 6 Wire rope hoist should have personnel operation. The operator should fully grasp the relevant knowledge about installation, maintenance and operation instructions.
 - 7 Not qualified personnel should not do the installation, maintenance and operation.
 - 8 Users must be sure that an install and maintenance personnel is familiar with instructions provided by the manufacturer.
 - 9 For the need of safe operation, the user must ensure that the instructions can be easily understood by operator.
 - 10 Operating personnel must carefully read the instructions and operation procedure.
 - 11 Users must be sure that the hoist installation on estimated impact load of the structure or hanging beam.
 - 12 User should ensure that wire rope hoist installation, positioning or fixed are reliable, so that will not due to accidental impact or other damage.
 - 13 The user should ensure that there will not occur obliquely pull when on load.
 - 14 User and the operator shall ensure that it will not exceed the rated load
 - 15 When several hoists lifting the same load, user should ensure that each hoist are fixed correctly, make each hoist's load will not exceed its rated load.
 - 16 Every time before shifting, the operator must check whether the emergency braking device is in good condition.
 - 17 When the operator found that wire rope hoist has obvious flaws (running gear, wheel, electric and bearing structure, etc.), it must be fixed immediately. If the operator does not have the skills or the maintenance work is not in the scope of their duties, must immediately stop operation and inform the related maintenance staff.
 - 18 The user should ensure that there will be no load hanging on the hook when the hoist is not in use.
 - 19 Personnel should not stand under the lifting objects.

-
- 20 The operator shall ensure that the load can be safe lifting and lifting area no idle personnel, and once received signal it can be start lifting load.
- 21 If it cannot observe the whole lifting movement from the control platform, operator must be careful to ensure there won't be any hurt to other people during operation process.
- 22 The operator shall not be allowed to leave the control platform when the lifting load is hung up.
- 23 If the operator has to leave the control platform when the lifting load is hung up, the user must protect the load at the bottom of the danger zone.
- 24 If the operator has to leave the control platform when the lifting load is hung up, the operator must protect the load at the bottom of the danger zone.
- 25 Hook load is prohibited to lifting people, and the electric hoist can never be used as lifting mechanism for manned elevator.
- 26 Users must not use steel wire rope electric hoist lifting casting material.
- 27 Electric hoist shall not be used to lift load that may be stuck or plug.
- 28 The lifting limit is not allowed to use repeatedly astravel switch.
- 29 The user cannot continue to use the electric hoist which has reached the theory safe use time.
- 30 If still want to use the electric hoist which has reached the theory safe use time, please refer to chapter 2.4.4.
- 31 Maintenance personnel should cut off the main power supply before maintenance and installation work.

2.3 Danger and damage

This product is mainly used for industrial control system. There will be some danger in the operation of internal parts and products of moving or rotating parts. Listed below may result in serious harm and property damage.

Move encloser when it is not allowed.

Incorrect use

Improper operation

Inadequate maintenance and protection

Not carefully read safety instruction can lead to hurt even death

If machine is operated by persons without enough training can lead to damage to body.

Operators and maintenance personnel must get enough training

Operators are allowed to wear inattentive cloths, stay long hair or wear jewelry.

Operators who are smoking or drunk cannot operate machine. Damaged parts of machine must be changed as soon as possible. Besides proof-explosion products, other products cannot used in situation with danger of explosion. Operators must strict follow operation manual to operate step by step.

Using improper or forbidden tools may lead damage to products. In order to make sure operators' safety, they must keep safety distance with machine.

Using flame around inflammable materials will be dangerous. Operators must escape this kind of wrong operation.

2.4 Safety working time

The safety working time of hoist depends on working duty and load spectrum (FEM 9.511).

The load spectrum is as bellow:

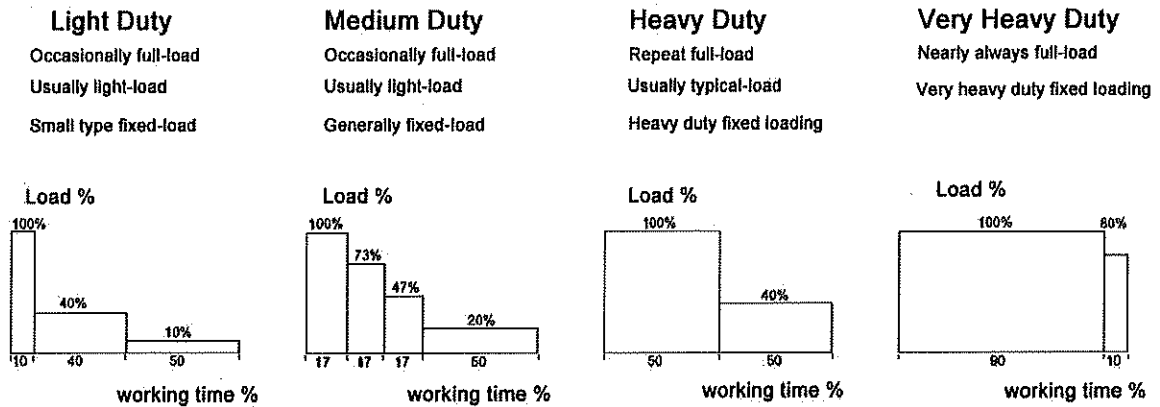

FEM has relevant standards about hoist's accidents caused by material fatigue and aging.

The following form is referred during designing of hoists.

Usage period		Work duty FEM (ISO)				
		1Bm(M3)	1Am(M4)	2m(M5)	3m(M6)	4m(M7)
Load spectrum	Light	3200	6300	12500	25000	50000
	Medium	1600	3200	6300	12500	25000
	heavy	800	1600	3200	6300	12500
	Very heavy	400	800	1600	3200	6300

2.4.1 Estimation of safety working time

Experienced service persons should timely check and record the service conditions of wire rope hoists, then estimate the remaining safety working time according to standard.

2.4.2 Solutions to the coming limit of safety working time

1. Stopping using wire rope hoists

2. If insist in keeping using them, professional personals should provide the following materials:

a) Professional association confirms hoists can be used continually.

b) Provide checking records and reports about continually using hoists

c) User accepts checking records and reports.

3 Technical descriptions

3.1 Structure and components

3.1.1 Configuration of wire rope

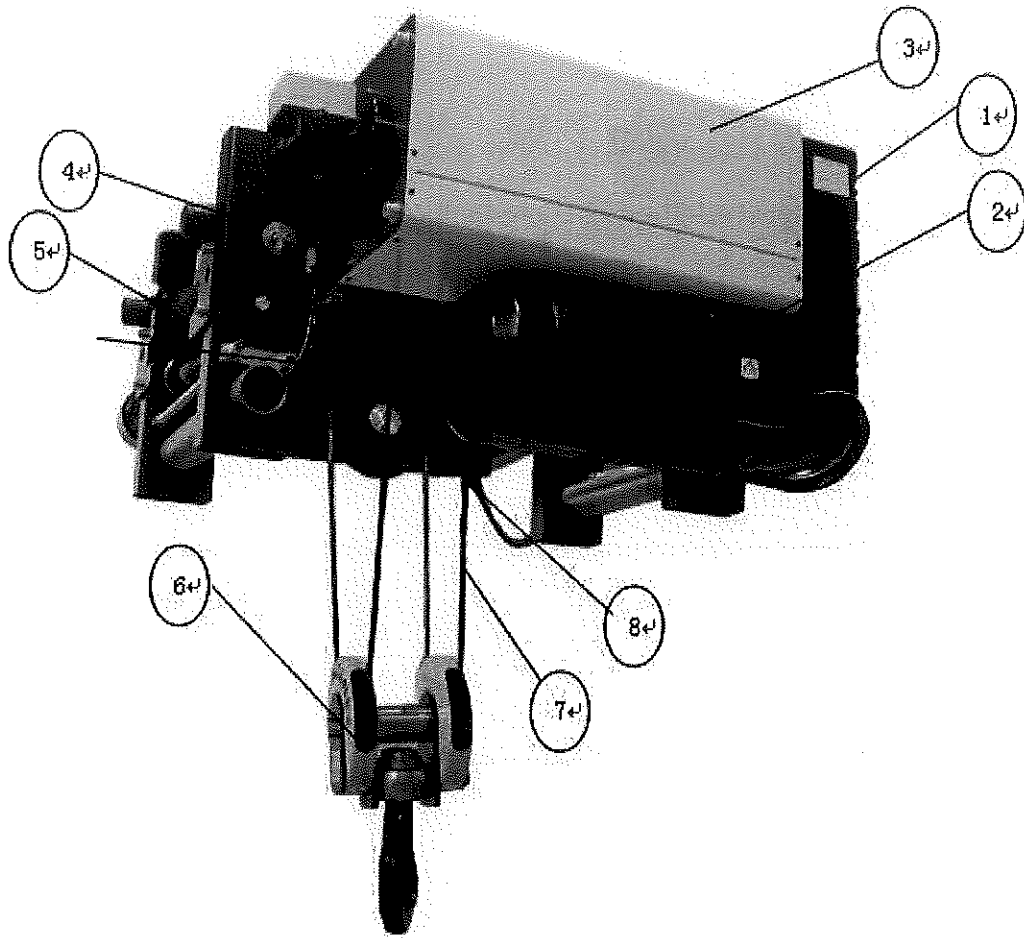

1. Hoisting transmission 2. Lifting motor 3. drum device 4. trolley frame 5. trolley traveling mechanism 6. hook 7. wire rope 8. Cabinet of hoist

3.1.2 Lifting motor

The standard lifting motor is double-speed motor or variable-frequency motor with disc brake.

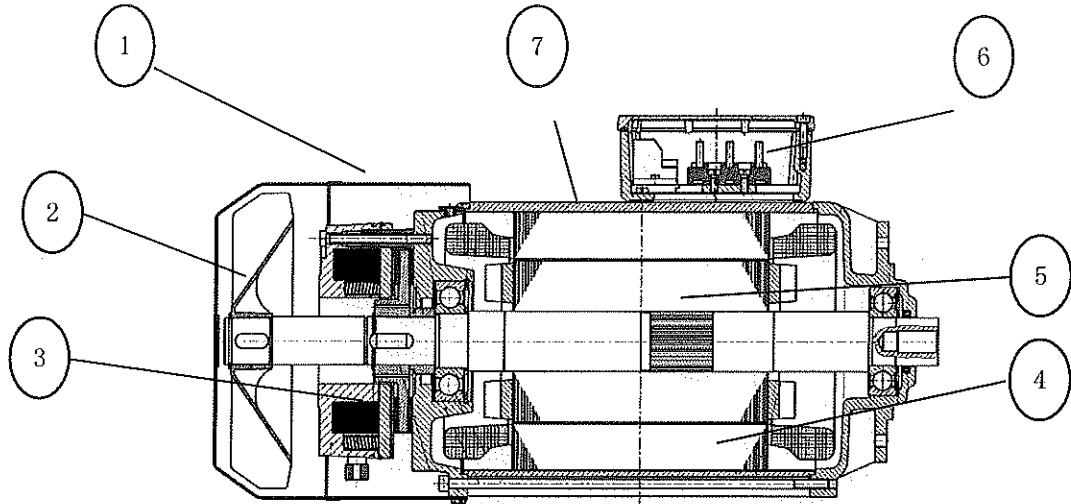

1. cover of fan 2. fan 3. breaker 4. stator 5. rotor 6. junction box 7. cover of motor

Double-speed (variable-frequency) motor has six (three) thermistors or sensors. The insulation level of motor is F. When the temperature is up to 150°C, thermistors or sensors will outage power of motor and when temperature is down to standard working temperature, the power will be on again.

The setting of lifting motor's nominal parameter should depend on condition that working operating ambient temperature not higher than 40°C and altitude not higher than 1000m. When environment elements change, motor's characteristics will change as well.

Lifting motor integrates electromagnetic disc brake (see figure below). When hoist is in the condition of stop or out-of power, electromagnetic disc brake will automatic closing.

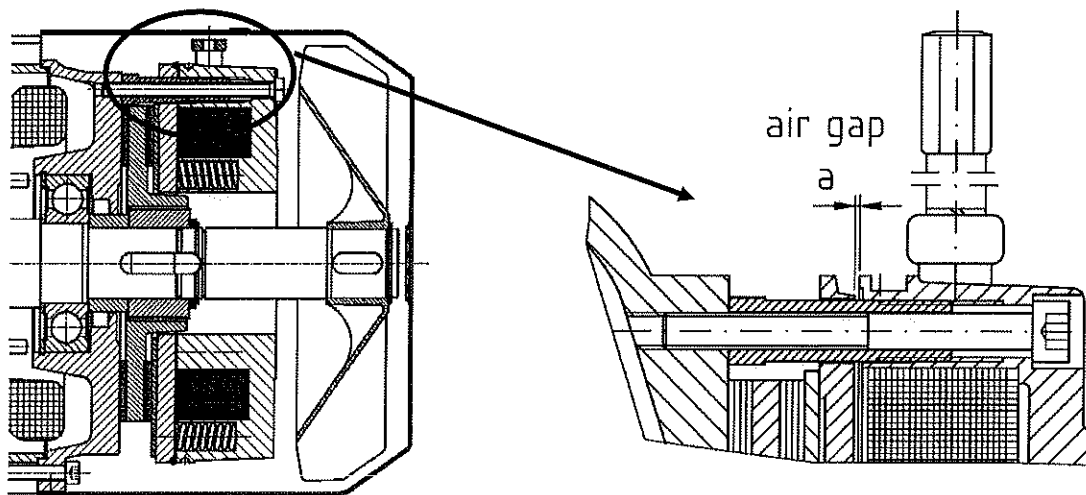

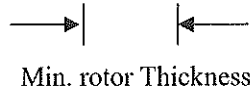

The IP grade of standard electromagnetic disc brake is IP54, the highest IP grade can be up to IP56. Meanwhile, electromagnetic disc brake can alternatively install manual release lever. Brake use dustproof design, which doesn't need other maintenance during normally operation.

Attention!

It is imperative to timely check brake clearance and thickness of brake disc.

Specific reference values of checking and adjustment are as below:

type	08	10	13	15	17	20	23	26	30
normal gap	0.2	0.2	0.3	0.3	0.3	0.4	0.4	0.5	0.5
maximum gap	0.6	0.7	0.8	0.9	1.0	1.1	1.1	1.2	1.2
minimum thickness of brake disc	4.5	5.5	7.5	9.5	11.5	12.5	14.5	16.5	16.5

Attention!

Checking and adjustment should be done by professional maintenance personnel. During this period, the hoist must be no-load and the main power must be cut.

3.1.3 Hoisting transmission

Drum is driven by gearbox. The output shaft is designed with involute spline so as to achieve best transmission function.

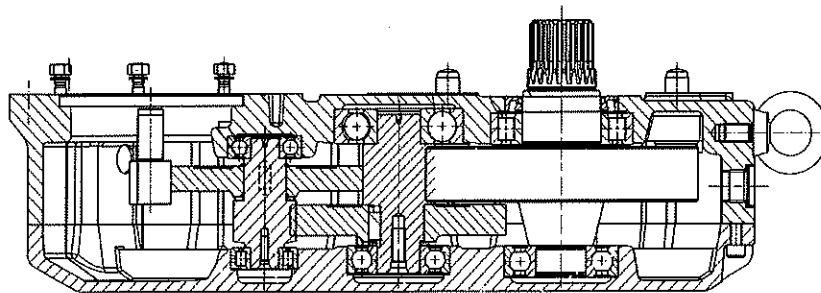

The design and lubrication of gearbox should strict follow FEM Standard, and it doesn't

need any other maintenance during safety working time if it is used normally. Gearbox has been filled up with lubrication before shipment. Please pay attention to type and quantity of lubrication oil listed in below form. Please make sure cover of gearbox are absolutely clean if you need to change lubrication oil.

If hoist is used in gelid environment, the lubrication oil must be changed into synthetic grease.

Time	Working content	Model of gearbox	Viscosity of lubrication oil	Volume of lubrication oil
Every six months or up to 3000 hours	State of lubrication oil	GH3201	VG680	1400
		GH5000A	VG220	4000
Every three years (operation under FEM)	Change lubrication oil (if it is mineral oil)	GH12500	VG680	5000
		GH20000	VG680	9000
Every five years (operation under FEM)	Change lubrication oil (if it is synthetic grease)	GH25000	VG220	13000
		GH40000	VG220	15000

If gearbox is working under adverse environment as below, it is very important to shorten maintenance cycle:

- Extreme wet
- Dust, acidity and other corrosive environment
- Environment with huge temperature difference

3.1.4 Drum device

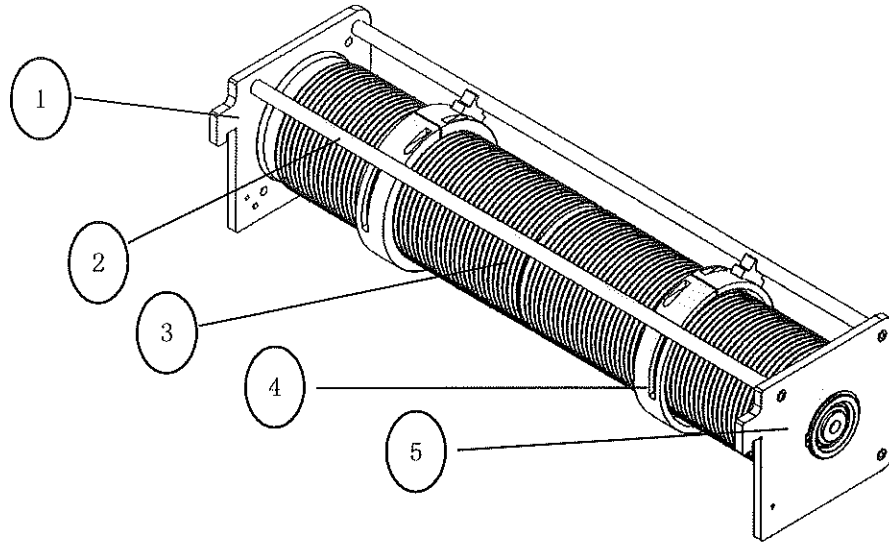

1. left plates 2. connecting rod 3. drum 4. rope guide 5. right plates
6. Lifting limiter

Drum is made of seamless tube, and its surface is processed into rope races according to different model, such as right-handed rotation or left-and-right handed rotation. Two ends of drum has flange.

Drum has guide, which is processed with wearable engineering plastics. Rope guide has rope races inside. It is cut from one cylinder, and then rebounded to elastic connecting with gasket, nut and spring. When assembly, bolts should not be twisted too tight. Holder of rope guide will move around along connecting rod when drum is turning, so that rope guide can always be in the right position. Holder of rope guide can also touch alternative limiter device.

Rope guide can make sure wire rope correctly wind on drum under normal operation. As to different winding methods, drum has one or two rope guide.

Rope guide made from engineering plastic can furthest reduce wire rope's wear.

Winding methods include single winding and double winding. The fixed connecting of single winding is as below. The assemble direction of wire rope and fixed connecting should be especially noticed when installation and maintenance.

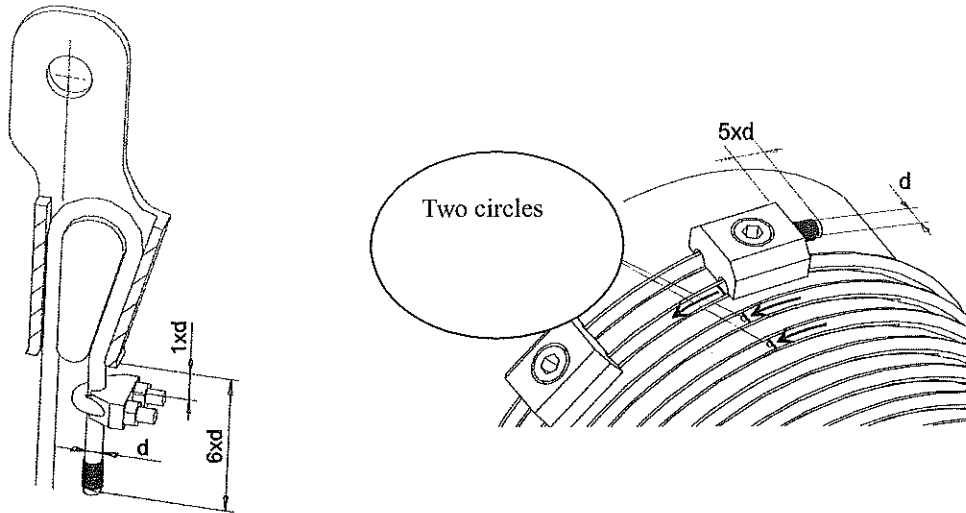

Ends of drum have press plates for wire. Models and quantity of press plates depend on hoist's model. According to safety standard, when hook is in the lowest position, there must be at least two circles at the end of drum.

3.1.4.1 Lifting limiter

wire rope hoist use screw type cam limit switch, which is installed on side plate of drum.

Screw type cam limit switch is precise and convenient for adjustment. The switch has two contactors to make sure the hoisting mechanism move in lower speed after touch limit position, which can effectively improve safety of operation.

3.1.5 Trolley frame

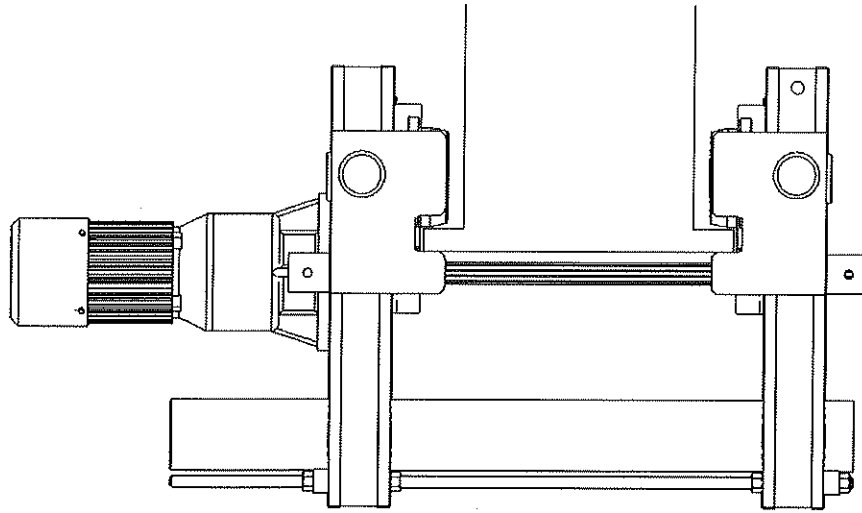

Trolley frame of double-girder hoist is constituted of connecting girder and end beams. Fixed pulleys overload limiter are installed inside connecting girder. The size of trolley frame depends on load, lifting height and some other elements of electrical hoists.

3.1.5.1 Overload limiter

Overload limiter will stop lifting if actual load is over rated load. Load protection is realized with electronic load sensor. Overload limiter's installation methods of single wind and double wind are as below:

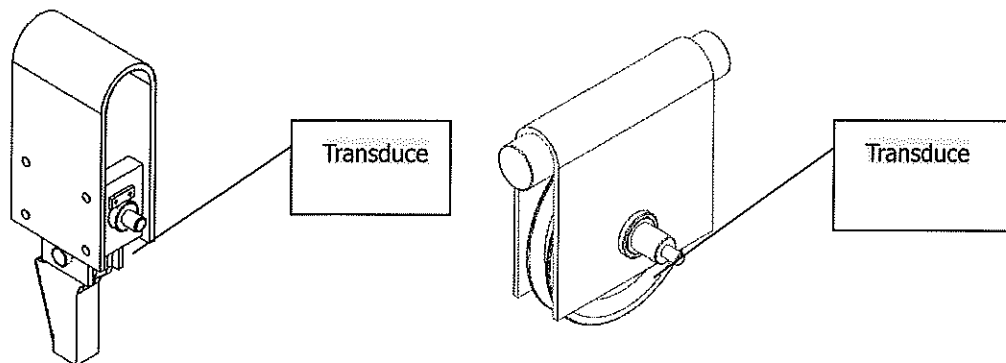

Attention!

Overload limiter has been verified with rated load in factory. When doing overload test on site, please turn off overload limiter, and then recover it after overload test. If the set value

of overload limiter is hugely different with actual situation, please contact hoist manufacturer or professional maintenance personnel to reset overload limiter.

3.1.6 Trolley travel mechanism

Travel mechanism includes squirrel-cage motor and gearbox.

Motor of standard configuration is frequency and protection level is IP54 and has thermistor. Electromagnetic disc brake is

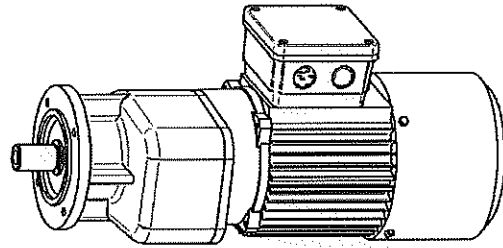

assembled on motor. The travel motor is designed and manufactured according to VDE0530, which can suffer 1.5 times of rated current in two minutes without damage wires inside motor.

Helical gearbox with parallel axle can improve transmission efficiency and reduce operation noise. Under normal operation, gearbox doesn't need to change lubrication oil during safety working time.

3.1.7 Wire rope

Wire rope is the main stressed part as well as vulnerable part of hoist. In order to make sure safety manufacturing, operators should strictly follow safety operation manual. Client should also timely check and maintain wire rope.

Routine maintenance includes:

- Visual inspection
 - Surface greasy dirty
 - Check transformation and wear
 - Check wire broken
 - Check corrosion situation
 - Check connectors
- Clean and lubrication (see attachment of Lubrication)

The inspection and scraping standard refers to ISO 4309:1990. Relevant data see to the

attachment.

Attention!

It is very important to timely inspect and maintain wire rope. Please immediately release load as soon as find abnormal situation about wire rope. And ask professional maintenance personnel to inspect it and change wire rope if necessary.

We suggest using crane components manufactured by

3.1.8 Hook assembly

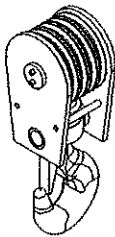

Hook assembly usually made up by following components:

- Hook forging
- Overhand card
- hook beam
- hanger plate
- pulley assembly

Hook is the main stressed part of electrical hoist. The daily inspection and maintenance of hook includes following content:

- if there are damage of hook forging and overhand card
- If hook can freely rotate or not
- Wearing situation of pulleys
- If cover of pulley rubs wire rope

Take different maintenance according to inspection results, such as change wearing parts or adding lubrication oil (see to attachment of Lubrication).

3.1.9 Hoist Electrical Control

Power supply for standard wire rope hoists are 380V/50Hz, and control power is 480V/50Hz. The lifting speed for standard wire rope is two speeds and traveling speed is variable speed. The outside view of the inverter as follows:

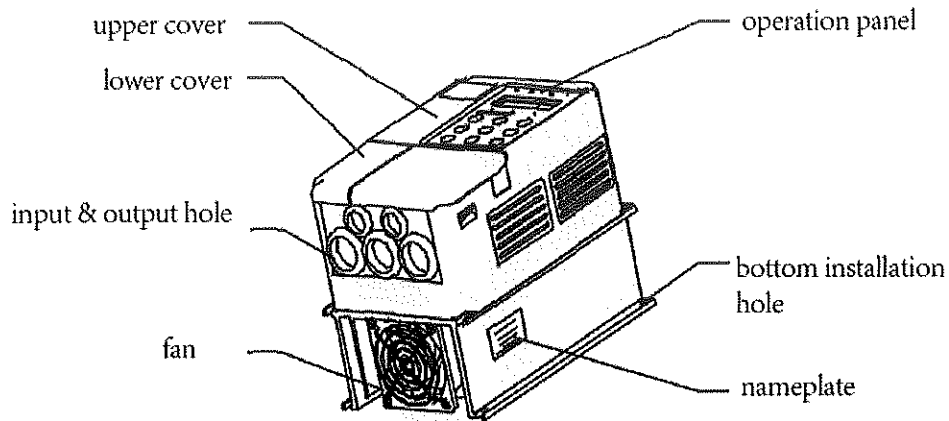

The inverter is used for trolley traveling speed control, and inverter data will be set before delivery according to the requirements in the contract.

Note!

After disconnecting the power, there is still high voltage in filter capacitor, so it is not allowed to do maintenance work for inverter immediately and must wait until the charge light is off and bus voltage is under 36V.

Because of the temperature, humidity, dust and vibration, the inter components of inverter will be aging, which will cause the potential breakdown and lifetime of inverter. So, it is needed to do the daily and periodical maintenance. Items needed to be checked as following:

- Whether abnormal change in motor sound during operation
- Whether there is vibration during motor operation.
- Whether the inverter install condition changed
- Whether the inverter cooling fan work normally.
- Whether the inverter overheating.

Keep inverter clean and clean dust on the surface to avoid it be into the inner part especially the metal dust.

Clean the oil on the inverter fan completely.

Items needed to be checked periodical as following:

-
- Check air duct, and regularly clean
 - Check screw (loosening or not)
 - Check inverter (corrosion or not)
 - Check terminal block (arc discharge or not)
 - Main circuit insulation test

Wearing parts include cooling fan and filter electrolytic capacitor, and the lifetime for these parts are closely related to the environment and maintenance.

Normal lifetime as following:

Fan 2-3 years

Electrolytic capacitor 4-5 years

Users can determine the replacement according to the running time and specific situation of parts.

3.2 Lubrication

Gearboxes and bearings has been added enough lubricant before delivery, under normal circumstance and within safe operation working time (SWP), no need to replace and add lubricant.

- Shell Super ATF
- DEA 5060
- ESSO ATF D 21611

Note!

Synthetic lubricants can't be mixed with mineral lubricants.

4 Assembly and Commissioning

Please read the operating manual and the relevant safety regulations carefully before hoist installation and maintenance.

Unless stated otherwise, the standard shipping status for hoist rope and hook have been assembled, the wheelbase or rail gauge wheels are manufactured and adjust to the position in accordance with the order. Electrical parts have been functional tested in factory, but lifting height limit is necessary to adjust in site.

If the wire rope hoist is not installed immediately it must be placed in a dry and clean place.

4.1 Preparation for Assembly

Before assembly and maintenance please confirm the conditions as following:

- enough personnel (quantity and skills)
- necessary tools and make sure the tools can use safety
- enough time(including assembly and commissioning time

Site work condition (Whether there is existence of the installation personnel and equipment safety problems, also need check whether the installed hoist used for working conditions)

Note!

Assembly work need be finished by professional personnel.

4.2 Hoist lifting

4.2.1 Single girder hoists

Width between the single girder trolley wheels (B1) has been adjusted before delivery. The dimension of B1 must be 4~5mm bigger than bottom width of support beam. Before assembly please confirm the dimension of B and B1. If the real dimension of B is different from the order and need to adjust B1, please contact with supplier.

- Loosen the nuts(1 and 3), and lock piece 2
- Lift the hoist on the support beam.
- Adjust the size and dimension of B1(about 5mm bigger than bottom width of support beam)
- Pre-tighten the lock nuts(1 and 3), check the parallelism of all the wheels, adjust the lock nuts if necessary
- Tighten the lock nuts

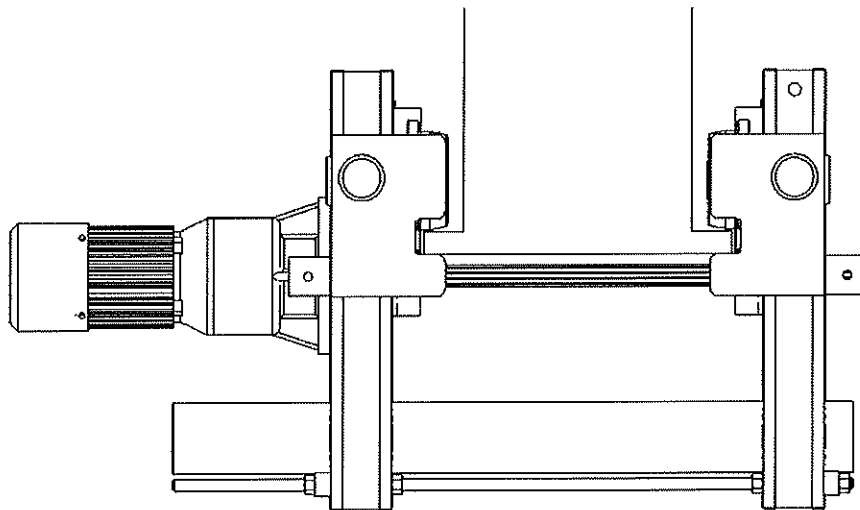

4.2.1 Double girder hoists

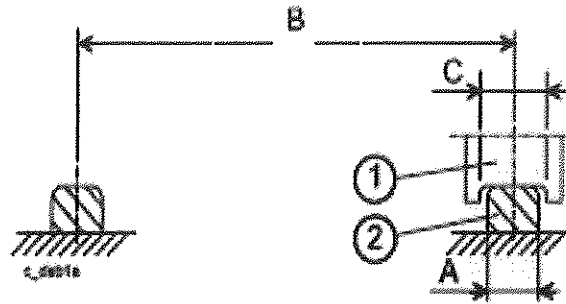

- Check the hoist wheel groove width (C) and rail tread width width (A), the standard condition is $C=A+15\text{mm}$
- Check whether the support beam rail center distance (B) consistent with the hoist gauge R. Standard conditions is $B = R \pm 2\text{mm}$
- Lift the hoist on the support beam and check the parallelism.

Before assembly please confirm the dimension of R and C, Which has been adjusted before delivery. If the real dimension of B is different from the order and need to adjust B1, please contact with supplier.

4.3 Check and Commissioning

4.3.1 No-load check

4.3.1.1 Electrical system

- Check whether the connection of electric device is same with the drawing
- check the cable connection
- check the main power switch (supplied by users)

According to the requirements of safe working practices, wire rope hoists shall be equipped with the main power switch. The main power switch should be installed near the main power line terminal for power inside, mainly used to cut off the main power supply during maintenance. Under emergency situations need use emergency stop switch.

When the wire rope hoist is installed as crane components, the crane control system should be equipped with the main power switch.

4.3.1.2 Pendant

Pendant push button control and fast cable joints are all optional configuration, if the order

contains they will be connect together and delivery with independent package.

Different control type has different outlook of the pendant control and cable connection.

- Check the whether pendant and pendant wire connections are good or not, pendant should hanging at a reasonable height.
- Press the direction button, it must be shown the direction on the button is same with the direction of movement.
- If there are errors on all the moving direction, can be corrected by changing the power supply phase sequence.
- Check the operation of the emergency stop button. Do not press the emergency stop button during normal operation.

4.3.1.3 Noise

When there is obviously noise for the hoist moving and lifting, please check if installed incorrectly.

- Feeling vibrations of hoists by manually moving and lifting.

If the hoisting motor makes continuous big noise and vibration, check and power supply phase sequence. If there is a large gourd mobile noise or excessive vibration, check the rail installation whether it meets specifications or not.

Before determine the cause of the noise, please do not use the hoist.

4.3.1.4 Lifting limit switch

Check and adjust the limit switch movement by put hook on its top and bottom position.

To be on the safe side, there must have adjustment on lifting limit switch before each test.

4.3.1.5 Traveling limit switch.

Check the limit switch operation condition by move the hoist its trigger position.

To be on the safe side, there must have adjustment on traveling lifting limit switch before each test.

4.3.1.6 Hook and sheaves

- Check the wire rope sheaves can rotate freely

-
- Check the hook can rotate freely

4.3.1.7 Wire rope

- Check and ensure no damage on wire rope during movement.
- Check whether the wire rope winding normally.
- Check the fastening condition on end of the wire rope.

New wire rope's load should be about 10% of the rated load. The load should be up to the total lifting height 5-10 times. If there appears wire rope winding, hook should be put at the lowest position when no load, open the end of the wire rope and rotary wedge until the winding disappeared.

4.3.1.8 Overload protection

- Check the Overload protection mechanism can operating normally.

4.3.1.9 Trolley frame

- Check the shaft distance and adjust correctly.
- Check and ensure all of the screw are tightened and fastened.
- There should be at least 3-5 round travel on the traveling beam.

4.3.1.9 Brake

- Check the brake operation of hoisting motor.

4.3.2 Load testing inspection (100% rated load)

4.3.2.1 Motor current

- Check each phase with rated load in the process of lifting movement.

Current should be balanced on all of the phases, no more than the motor rated current.

Check the current under two hoisting speed.

4.3.2.2 Motor Operating Temperature

If thermal protection makes the lifting movement stop too early, find out the cause of the

overheating before continue test.

4.3.2.3 Traveling mechanism

- check whether the accelerator and brake can operate normally.
- Move left and right 3~5 times on the whole length of the main girder and the rail can't be painted.

4.3.3 Check under overload (110...125% of rated load)

4.3.3.1 Overload protection device

- Check the overload device during overload operation.

When operate with the overload, the overload device can stop the movements.

4.3.3.2 Brake

- Put down the load and stop with the low speed and brake can work normally.

4.3.4 Data and records

- Check the files delivered together with the hoist. Ensure the entries are in a proper manner, and the reference data is in accordance with the nameplates.

- Write hoist debugging log. Put together the log with other documents of the hoist.

In order to ensure safe production, electric hoist manufacturer can arrange user training through a separate agreement.

5 Operating manual

5.1 Pendant control

The standard control mode of lifting and traversing movement of the wire rope electric is by the pendant. For other control solutions, please confirm with before ordering.

Lifting motor is controlled by two-speed button. To start the hoist, a skilled operator will always start slowly (the first stage) and then transition to a rapid speed (second level).

When lowering the load, a skilled operator will lower the goods by a high speed to an appropriate height then use low speed to put down the load to the appointed location.

The mechanical locking device in the controller is to prevent the reverse action when the opposite action buttons are pressed. Pay attention to avoid frequent starts during the operation.

By pendant can achieve the following controls:

- Release the button => Stop
- Press the first level => slow (see below)
- All Press => fast (see below)

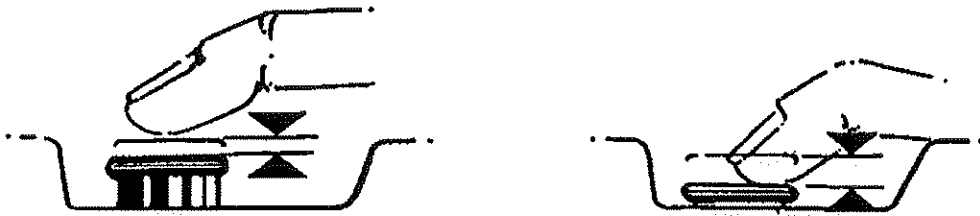

- Press the red emergency stop button => to stop all actions (see below)
- clockwise rotate the emergency stop button => to restore the original action (see below)

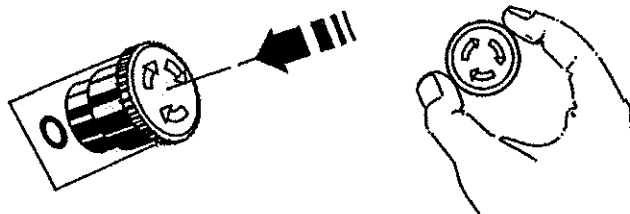

5.2 Loading type

Load should be hung onto the hook for elevation. It is strictly prohibited to pull obliquely during lifting. Use an auxiliary lifter if necessary.

Before lifting ensure the load has been well fixed, and hook safety buckle in the closed state.

If the rope is in a relaxed state before lifting, need to carefully check whether the wire rope has knots or is seriously distorted after lift up. During the lifting process, operator or assistant operator must ensure that the hook always within his sight.

6 Inspection and repair

6.1 Inspection

Notice

User or an appointed third party should carry out acceptance test when receive the goods.

Acceptance and testing personnel must meet the following requirements:

- Must have good mechanical, electrical, and wire rope hoists technical background
- have enough experience of rope hoist installation, service and maintenance
- Familiar with relevant safety practices

6.1.1 Inspection test before the first start-up

Users should ensure that wire rope hoists, load bearing and load bearing structures is tested by experienced personnel before the first start-up

The following items must be checked during the inspection and testing:

- If the technical parameter of the wire rope hoist is consistent with the nameplate
- If there's any violation of safety norms during design and manufacture.
- Safety devices such as limit switches, brakes and others operate normally

There shouldn't be any defects in the wire rope hoists, load bearing and load bearing structures that may affect the safe operation and personnel safety defects.

- All structural inspection and testing results should be recorded in the maintenance plan form
- Based on the results of inspections and tests, specialized inspector shall decide whether to do load debugging
- If any defects found during load debugging, specialized inspectors shall have the right to re-test.

Notice

According to different requirement of local safety department, the content of inspection and test may be different. If the load testing require to do 1.1 times of rated load for dynamic test and 1.25 times of rated load for static test, please contact with manufacturer of hoists about this.

6.1.2 Acceptance tests after overhaul and significant changes

Please do acceptance tests to wire rope hoist which has been overhauled and significantly changed refer to 6.1.1.

Overhaul and significant changes include:

- move hoist and use it in other bearing structure
- weld in existing bearing structure
- design change of existing structure

Notice

Crane should be tested and accepted according to relevant standards if wire rope hoist is used as it lifting equipment.

6.1.3 Routine inspection

For safety, professional personnel should inspect wire rope hoist as well as its bearing structure at least once a year. As to wire rope hoist which often used nearly rated load, should be test more frequently. Hoists used in wicked situation should also be tested more frequently. User can also consult manufacturer about routine inspection, especially about doubts of inspection results.

Routine inspection includes:

- Check hoists identities according to technical data in inspection schedule
- Check if hoists and parts are broken, wear or corroded
- Check if safety protection device (limiter, emergency stop) and brake are operated well
- Check bearing structure
- Count remaining safety working time

Notice

1. Stop using wire rope hoist if it has approached at theoretic safety working life
2. If insist in continuing using this wire rope hoist, professional personnel should provide below document:

- a) Confirm hoist can be used continually
 - b) Inspection report
3. User's acceptance of inspection result and report

6.2 Inspection Plan

Parts	Inspection content	Inspection cycle		
		Commissioning	Daily	regular
Brake	Functional Testing	X	X	X
	Brake gap			X
Overload limiter	Functional Testing	X		X
Wire rope	Visual damage situation		X	X
	Lubricating	X	X	X
	Wearing situation			X
Rope guide	Visual appearance and Accessories	X		X
Hooks	Visual damage situation		X	X
	If safe lock can rotate freely	X	X	X
	If safe lock can rotate freely	X	X	X
	Wearing of hook			X
Electronic control	Functional Testing	X	X	X
	If wire is loose			X
Limiting stopper of lifting	Functional Testing	X	X	X

Attention!

Only well-trained and authorized technical personnel can maintain and service electrical wire rope cranes of.

will not take responsible for any quality events caused by non-authorized or incorrect maintenance. Please must use original spare parts of, in order to ensure the effectiveness of quality assurance provisions.

6.3 Maintenance and replacement of wire rope

6.3.1 Inspections of wire rope

Wire's fracture will happen during normal using, because of continue wearing and fatigue stress. For security reasons, it is necessary to check wire rope once a month. The wire rope must be changed if anyone of following three situations happens: number of fracture more than 4% of total amount within the distance no longer than 6 times of wire rope's nominal diameter (FEM 1Bm~1Am); number of fracture more than 8% of total amount within the distance no longer than 30 times of wire rope's nominal diameter (FEM 2m~4m); broken of wire rope's strands. In addition, if wire rope has suffered severely mechanical injury, such as deformation of cage type, permanent deformation and so on, it must be changed immediately.

6.3.2 Maintenance and lubrication of wire rope

User should do necessary lubrication depending on usage. The idea lubrication method is using cotton cloth wetted by worm lubrication oil to scrub the whole wire rope. If wire rope cannot be lubricated because of special situation, service life of wire rope must be shortened and users should do more frequent inspections.

6.3.3 Replacement of wire rope

- Put empty hook on the holder and strike cover of drum. Take out rope from the fixed end and then release rope guide. Then release the whole wire rope and lease bolts of press plates, and then take out the whole wire rope.
- According to standards of ISO4309, release the whole wire rope and fix the wire rope at the end of drum depending on torque required from pressing plate (see to chart of pressing).
- Start motor to wind wire rope on drum, and then cross another end of wire rope through hook pulley, fixed pulley and fixed wedge block.
- Putting the wedge into wedge block, frapping wire rope, then fix rope clips to the end of rope after correct installation.
- Reinstall rope guide on drum after cleaning and lubricating.
- Check again if wedge block, wire rope and wire rope are installed correctly, as well as confirm the lifting limiter is working normally.

-
- Put hook in the naturally vertical state to visually check if the hook is horizontal rotation. If the hook is horizontal rotation, release wire rope from the fixed end to release stress.

6.4 Cleaning and lubrication of rope guide

During normal use, rope guide will get enough lubrication through the lubrication of wire rope. It is also necessary to separately lubricate rope guide when check hoist. When lubricating, rope guide should be taken from drum and then wipe some lubrication oil on the friction surface.

7 Faults handling

Attention!

The power must be cut off before any fault handling.

Faults description	Possible causes	Handling methods	Remarks
Hoist doesn't operate	No power	Check power supply and collector Check emergency stop and contactor KI	
	Lifting limiter is touched	Check phase sequence of main power Check limiters	
Lifting motor doesn't operate	No power	Check voltage of main power	
	wiring error of main power's supply line	Re-wiring correctly	
	Fuse error	Replace new fuse	
	Malfunction of Push Button	Check buttons and wiring of buttons	
Lifting motor does not move, but has "Mu" sound when pressing buttons	Wiring error	Check wiring of incoming lines of main power	Motor probable be broken
	Contactor error	Replace contactor	
	Brake doesn't open	Refer to the handling of brake errors	
Single-direction movement of lifting	Faults of push button	Check buttons and replace them if necessary	
	Wiring faults	Check wiring	
	Lifting limiter is touched	Check limiter	
	Faults of contactor	Check contactor	
Brake doesn't operate	Power supply failures of brake coils	Check wiring/ change or maintain broken brake coils	
	Failures of rectifier	Check wiring and power supply of brake coils Replace broken rectifier	
Braking length is too large	Clearance of brake disc	Adjust clearance	
Excessively fast wearing of wire rope	Insufficient lubrication of wire rope	Lubricate wire rope timely	
	Solid attachments on wire rope	Clean wire rope timely	
	Pulleys are broken because extreme using	Replace new parts	

1 2 3 4 5 6 7 8

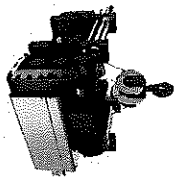

Electric Wiring Diagram

Project No: NW0106249901

System No: NWKG20240601467

Specifications: NWHS 10t12m

Date: 2024-06-20

System Code: N080103-000008A-N-48V-1

Design		Date	
Drawing		Preceding	
Standard		Audit	
Amendment		Original project	

Electrical schematic diagram

Designer

Project specification and model

NW0106249901

Pages

Pagecount

3

2

1

8

8

A

B

C

D

E

F

