



NCH Electric Chain Hoist Code

NCH	2	07	1	100	08	M
------------	----------	-----------	----------	------------	-----------	----------

No.	Code	Description	Notes / Properties
1	NCH	Electric Chain Hoist Code	
2	2	Series Code	1, 2, 5 refer to NCH1, NCH2, NCH5 series
3	07	Chain Diameter	05 Chain Specification: 5 x 15 07 Chain Specification: 7 x 21 09 Chain Specification: 9 x 27 11 Chain Specification: 11 x 31
4	1	Number of Falls	1 Single Fall Load Lifting 2 Double Fall Load Lifting
5	100	Rated Load Capacity	050 1) 050=50 x 10kg=500kg 100 2) 100=100 x 10kg=1000kg
6	08	Lifting Speed	03 Hoist Lifting Speed: 3.2/0.75m/min 04 Hoist Lifting Speed: 4/1m/min 06 Hoist Lifting Speed: 6.3/1.6m/min 08 Hoist Lifting Speed: 8/2m/min 16 Hoist Lifting Speed: 16/4m/min
7	M	Structure Type	F Fixed Electric Chain Hoist P Manual Trolley Electric Chain Hoist M Monorail type Electric Chain Hoist E Crane type Electric Chain Hoist

Selection Table of NCH Electric Chain Hoist

Load Capacity (kg)	Hoist Model	F.E.M	ISO	Number of Falls	Lifting Speed (m/min)	Lifting Power (kw)	Type
250kg	NCH1051 02508	3m	M6	1	8/2	0.75/0.18	F/P/M/E
250kg	NCH1051 02516	1Am	M4	1	16/4	0.75/0.18	F/P/M/E
320kg	NCH1051 03208	2m	M5	1	8/2	0.75/0.18	F/P/M/E
500kg	NCH1051 05008	1Am	M4	1	8/2	0.75/0.18	F/P/M/E
500kg	NCH2071 05008	3m	M6	1	8/2	1.9/0.45	F/P/M/E
500kg	NCH2071 05016	2m	M5	1	16/4	1.9/0.45	F/P/M/E
630kg	NCH1052 06304	2m	M5	2	4/1	0.75/0.18	F/P/M/E
630kg	NCH2071 06308	3m	M6	1	8/2	1.9/0.45	F/P/M/E
1000kg	NCH1052 10004	1Am	M4	2	4/1	0.75/0.18	F/P/M/E
1000kg	NCH2071 10008	2m	M5	1	8/2	1.9/0.45	F/P/M/E
1000kg	NCH5091 10016	1Am	M4	1	16/4	3.5/0.86	F/M/E
1600kg	NCH2072 16004	3m	M6	2	4/1	1.9/0.45	F/P/M/E
1600kg	NCH5091 16008	2m	M5	1	8/2	3.5/0.86	F/M/E
2000kg	NCH2072 20004	2m	M5	2	4/1	1.9/0.45	F/P/M/E
2000kg	NCH5111 20008	1Am	M4	1	8/2	3.5/0.86	F/M/E
2000kg	NCH5111 20006	2m	M5	1	6.3/1.6	3.5/0.86	F/M/E
2500kg	NCH5092 25004	2m	M5	2	4/1	3.5/0.86	F/M/E
2500kg	NCH5111 25006	1Am	M4	1	6.3/1.6	3.5/0.86	F/M/E
3200kg	NCH5092 32004	1Am	M4	2	4/1	3.5/0.86	F/M/E
3200kg	NCH5112 32003	3m	M6	2	3.2/0.75	3.5/0.86	F/M/E
4000kg	NCH5112 40003	2m	M5	2	3.2/0.75	3.5/0.86	F/M/E
4000kg	NCH5112 40004	1Am	M4	2	4/1	3.5/0.86	F/M/E
5000kg	NCH5112 50003	1Am	M4	2	3.2/0.75	3.5/0.86	F/M/E

Note: For other non-standard tonnage hoists, please check with sales from Novocrane.

NCH1 Fixed Type Electric Chain Hoist (F) -1 Fall

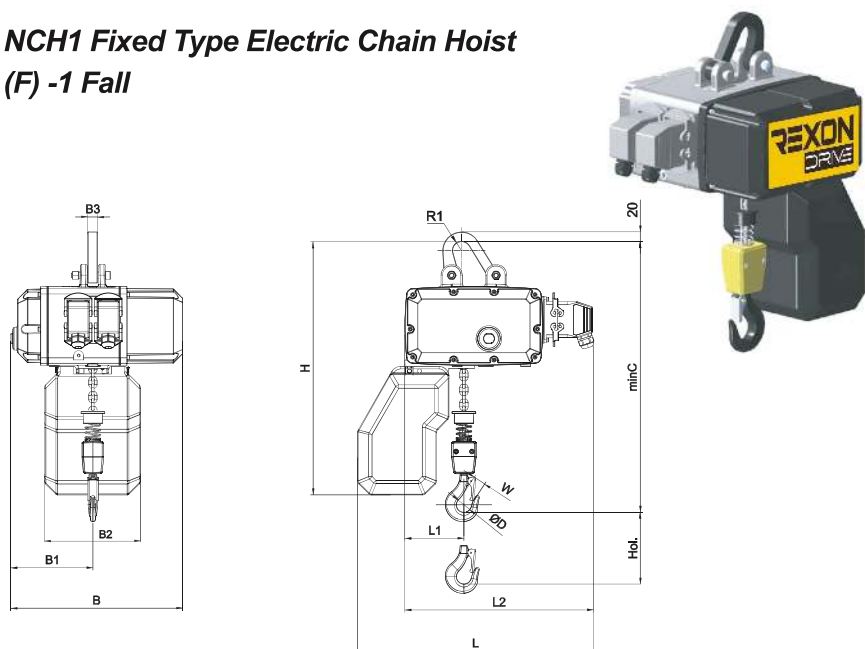

NCH2 Fixed Type Electric Chain Hoist (F) -1 Fall

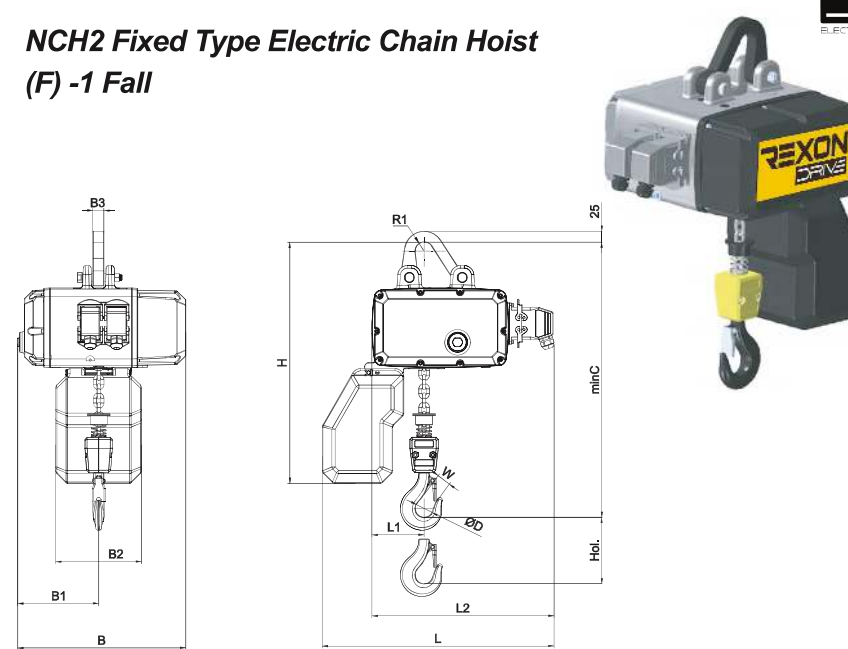

Product Dimensions and Parameters

size (mm)	Rated Load Capacity		Relevant Parameter	
	320kg	500kg		
B	348.5		Lifting Motor Power kw	0.75/0.18
B1	166.5		Lifting Motor RPM r/min	2860/740
B2	195		Trolley Motor Power kw	/
B3	20		Trolley Motor RPM r/min	/
L	478.5		Trolley Speed m/min	/
L1	115		Protection Class	IP54
L2	383			
H	Hol ≤ 12m	512	Insulation Class	F
	Hol ≤ 28m	662		
R1	18		Total Weight/kg	30+(Hol-3)*0.55
W	27			
D	34			
C	465	475		
Applicable Model for Overall Dimensions	NCH1051 02508F	NCH1051 05008F		
	NCH1051 03208F			
	NCH1051 02516F			

Product Dimensions and Parameters

size (mm)	Rated Load Capacity		Relevant Parameter	
	1000kg			
B	381.5		Lifting Motor Power kw	1.9/0.45
B1	184		Lifting Motor RPM r/min	2860/740
B2	195		Trolley Motor Power kw	/
B3	25		Trolley Motor RPM r/min	/
L	526		Trolley Speed m/min	/
L1	118.5		Protection Class	IP54
L2	413			
H	Hol ≤ 8m	547	Insulation Class	F
	Hol ≤ 16m	697		
R1	20		Total Weight/kg	49+(Hol-3)*1.08
W	32			
D	40			
C	519			
Applicable Model for Overall Dimensions	NCH2071 05008F	NCH2071 10008F		
	NCH2071 05016F			
	NCH2071 06308F			

NCH5 Fixed Type Electric Chain Hoist (F) -1 Fall

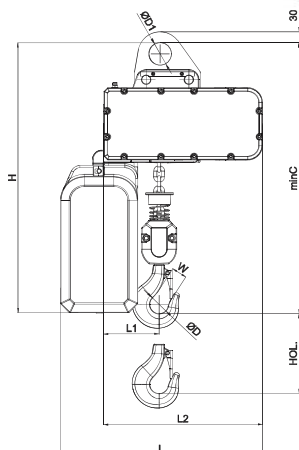
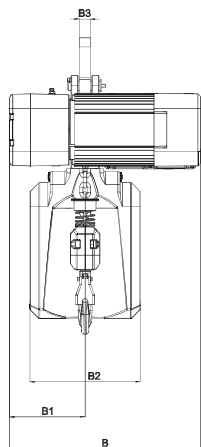

NCH1 Fixed Type Electric Chain Hoist (F) -2 Falls

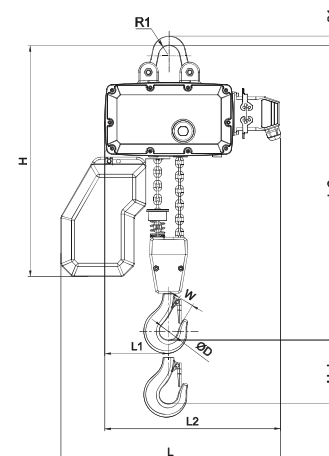
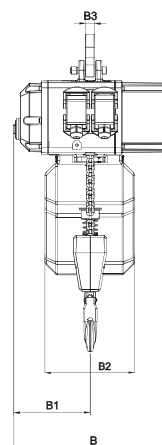

Product Dimensions and Parameters

size (mm)		Rated Load Capacity		Relevant Parameter	
		1600kg	2500kg		
B		519		Lifting Motor Power kw	3.5/0.86
B1		205			
B2		300		Lifting Motor RPM r/min	2860/740
B3		30			
L		549		Trolley Motor Power kw	/
L1		270	268		
L2		432		Trolley Motor RPM r/min	/
H	Hol ≤ 16m	733	/		
	Hol ≤ 12m	/	733		
D1		60		Protection Class	IP54
W		38	40		
D		48	50	Insulation Class	F
C		643	650		
Applicable Model for Overall Dimensions		NCH5091 10016F NCH5091 16008F	NCH5111 20008F	119+(Hol-3)*1.77	
			NCH5111 20006F NCH5111 25006F	2500kg: Total Weight/kg	
		123+(Hol-3)*2.81			

Product Dimensions and Parameters

size (mm)		Rated Load Capacity		Relevant Parameter	
		1000kg			
B		348.5		Lifting Motor Power kw	0.75/0.18
B1		166.5			
B2		195		Lifting Motor RPM r/min	2860/740
B3		20			
L		478.5		Trolley Motor Power kw	/
L1		139			
L2		383		Trolley Motor RPM r/min	/
H	Hol ≤ 6m	503			
	Hol ≤ 14m	653			
R1		22.5		Protection Class	IP54
W		32			
D		40		Insulation Class	F
C		525.5			
Applicable Model for Overall Dimensions		NCH1052 06304F	NCH1052 10004F	Total Weight/kg	
				33+(Hol-3)*1.1	

NCH2 Fixed Type Electric Chain Hoist (F) -2 Falls

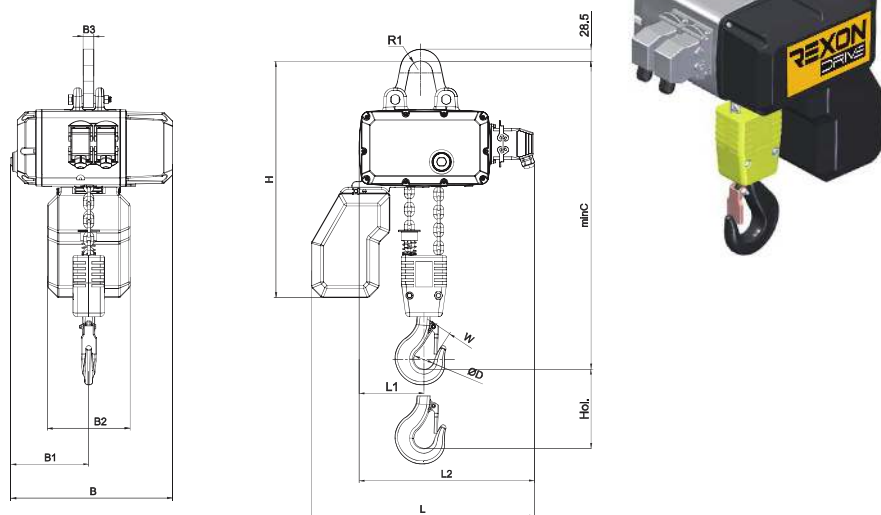

Product Dimensions and Parameters

size (mm)		Rated Load Capacity		Relevant Parameter	
		2000kg			
B		381.5		Lifting Motor Power kw	1.9/0.45
B1		184			
B2		195			
B3		25		Lifting Motor RPM r/min	2860/740
L		526			
L1		152		Trolley Motor Power kw	/
L2		413			
H	Hol ≤ 4m	557		Trolley Motor RPM r/min	/
	Hol ≤ 8m	707			
R1		27.5		Trolley Speed m/min	/
W		40			
D		50		Protection Class	IP54
C		630			
Applicable Model for Overall Dimensions		NCH2072 16004F NCH2072 20004F		Insulation Class	F
				56+(Hol-3)*2.16	

NCH5 Fixed Type Electric Chain Hoist (F) -2 Falls

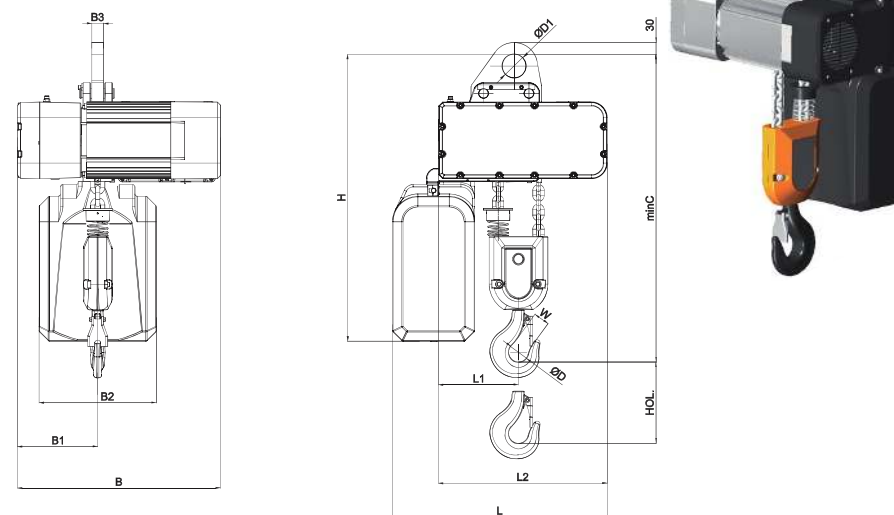

Product Dimensions and Parameters

size (mm)		Rated Load Capacity		Relevant Parameter	
		3200kg	5000kg		
B		519		Lifting Motor Power kw	3.5/0.86
B1		205			
B2		300			
B3		30		Lifting Motor RPM r/min	2860/740
L		549			
L1		322	311.5	Trolley Motor Power kw	/
L2		432			
H	Hol ≤ 8m	733	/	Trolley Motor RPM r/min	/
	Hol ≤ 6m	/	733		
D1		60		Trolley Speed m/min	/
W		40	45		
D		50	56	Protection Class	IP54
C		720	754		
Applicable Model for Overall Dimensions		NCH5092 25004F NCH5092 32004F		Insulation Class	F
				125+(Hol-3)*3.54	
Applicable Model for Overall Dimensions		NCH5112 32003F NCH5112 40004F NCH5112 40003F NCH5112 50003F		5000kg: Total Weight/kg	/

NCH1 Monorail/ Crane Type Electric Chain Hoist (M/E type) -1 Fall

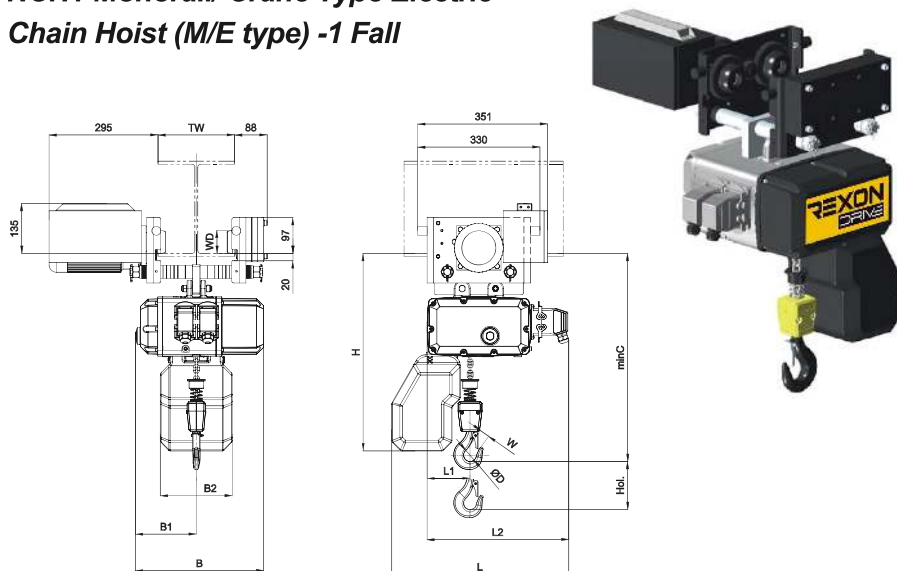

NCH2 Monorail/ Crane Type Electric Chain Hoist (M/E type) -1 Fall

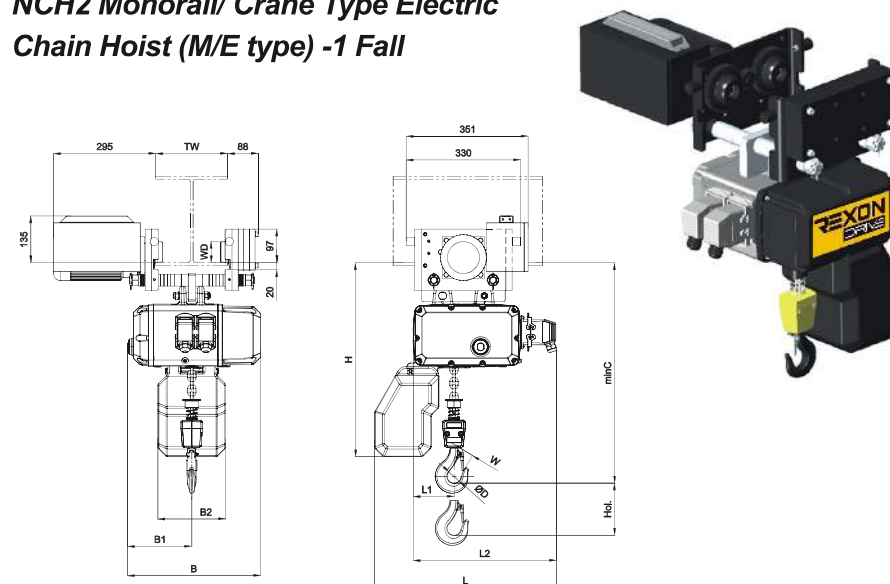

Product Dimensions and Parameters

size (mm)	Rated Load Capacity		Relevant Parameter	
	320kg	500kg		
B	348.5		Lifting Motor Power kw	0.75/0.18
B1	166.5			
B2	195		Lifting Motor RPM r/min	2860/740
TW	50-230			
L	478.5		Trolley Motor Power kw	0.2
L1	115			
L2	383		Trolley Motor RPM r/min	1400
H	≤ 12m	540		
	≤ 28m	690		
WD	62		Protection Class	IP54
W	27			
D	34		Insulation Class	F
C	490	500		
Applicable Model for Overall Dimensions	NCH1051 02508M/E	NCH1051 05008M/E	Total Weight/kg 56+(Hol-3)*0.55	
	NCH1051 03208M/E			
	NCH1051 02516M/E			

Product Dimensions and Parameters

size (mm)	Rated Load Capacity		Relevant Parameter	
	1000kg			
B	381.5		Lifting Motor Power kw	1.9/0.45
B1	184			
B2	195		Lifting Motor RPM r/min	2860/740
TW	50-230			
L	526		Trolley Motor Power kw	0.2
L1	118.5			
L2	413		Trolley Motor RPM r/min	1400
H	Hol ≤ 8m	560		
	Hol ≤ 16m	710		
WD	62		Protection Class	IP54
W	32			
D	40		Insulation Class	F
C	540			
Applicable Model for Overall Dimensions	NCH2071 05008M/E	NCH2071 05016M/E	Total Weight/kg 75+(Hol-3)*1.08	
	NCH2071 06308M/E			
	NCH2071 10008M/E			

NCH5 Monorail/ Crane Type Electric Chain Hoist (M/E type) -1 Fall

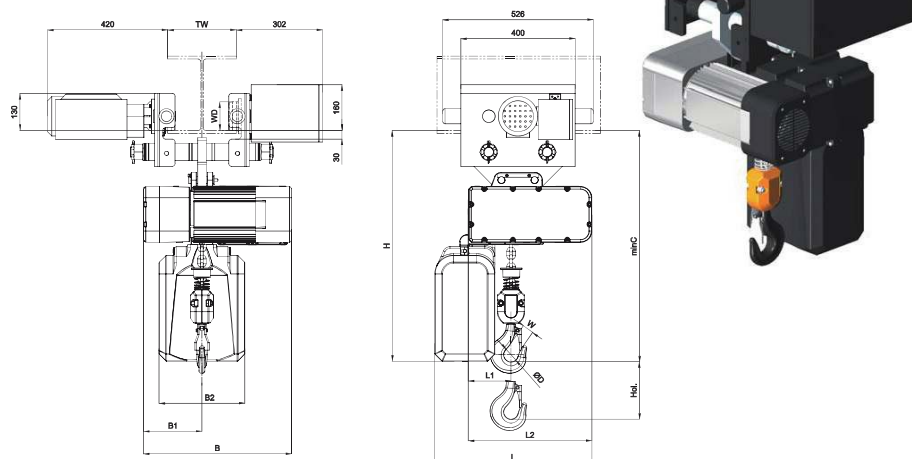

NCH1 Monorail/ Crane Type Electric Chain Hoist (M/E type) -2 Falls

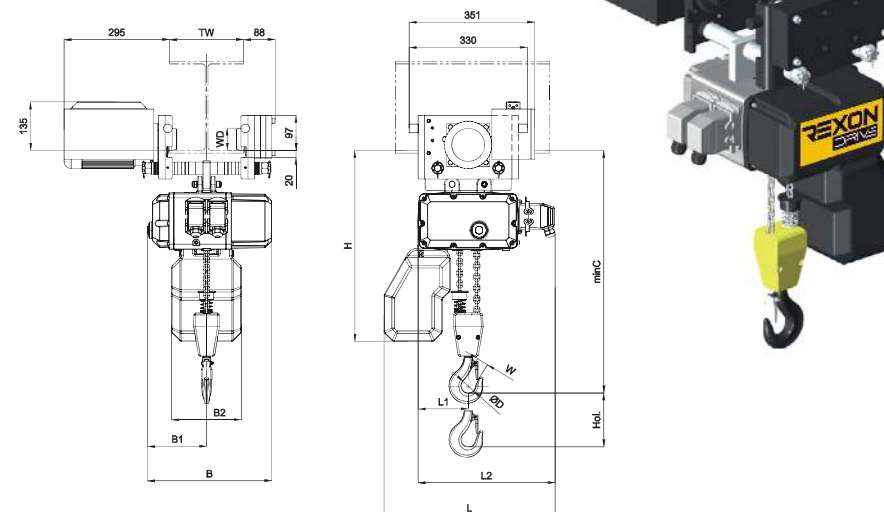

Product Dimensions and Parameters

size (mm)	Rated Load Capacity		Relevant Parameter	
	1600kg	2500kg		
B	519		Lifting Motor Power kw	3.5/0.86
B1	205			
B2	300			
TW	80-300		Lifting Motor RPM r/min	2860/740
L	549			
L1	270	268	Trolley Motor Power kw	0.64
L2	432			
H	HoL ≤ 16m	733	Trolley Motor RPM r/min	2410
	HoL ≤ 12m	/		
WD	100		Trolley Speed m/min	5-20
W	38	40		
D	48	50	Protection Class	IP54
C	725	728	Insulation Class	F
Applicable Model for Overall Dimensions	NCH5091 10016M/E NCH5091 16008M/E	NCH5111 20008M/E NCH5111 20006M/E NCH5111 25006M/E	1600kg: Total Weight/kg	
			185+(HoL-3)*1.77	
			2500kg: Total Weight/kg	
		189+(HoL-3)*2.81		

Product Dimensions and Parameters

size (mm)	Rated Load Capacity		Relevant Parameter	
	1000kg			
B	348.5		Lifting Motor Power kw	0.75/0.18
B1	166.5			
B2	195			
TW	50-230		Lifting Motor RPM r/min	2860/740
L	478.5			
L1	139		Trolley Motor Power kw	0.2
L2	383			
H	HoL ≤ 6m	540	Trolley Motor RPM r/min	1400
	HoL ≤ 14m	690		
WD	62		Trolley Speed m/min	5-20
W	32			
D	40		Protection Class	IP54
C	562.5		Insulation Class	F
Applicable Model for Overall Dimensions	NCH1052 06304M/E NCH1052 10004M/E	Total Weight/kg		
		59+(HoL-3)*1.1		

NCH2 Monorail/ Crane Type Electric Chain Hoist (M/E type) -2 Falls

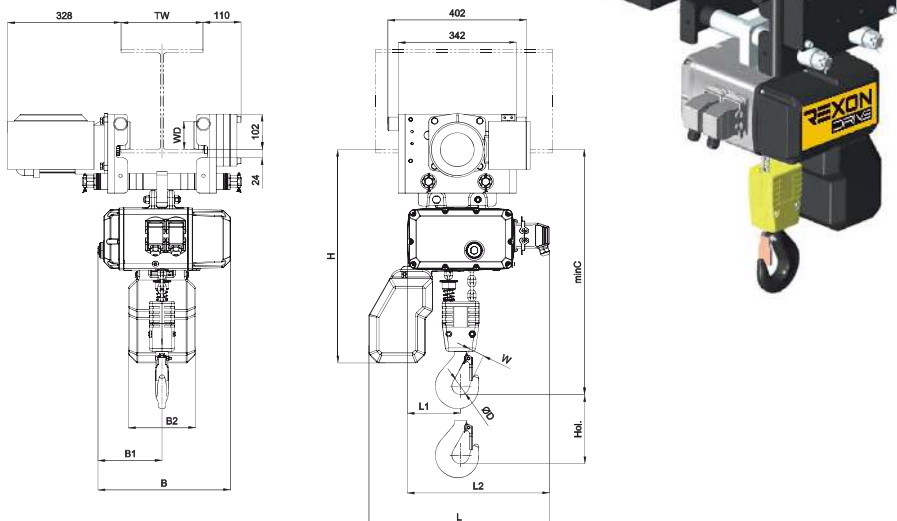

NCH5 Monorail/ Crane Type Electric Chain Hoist (M/E type) -2 Falls

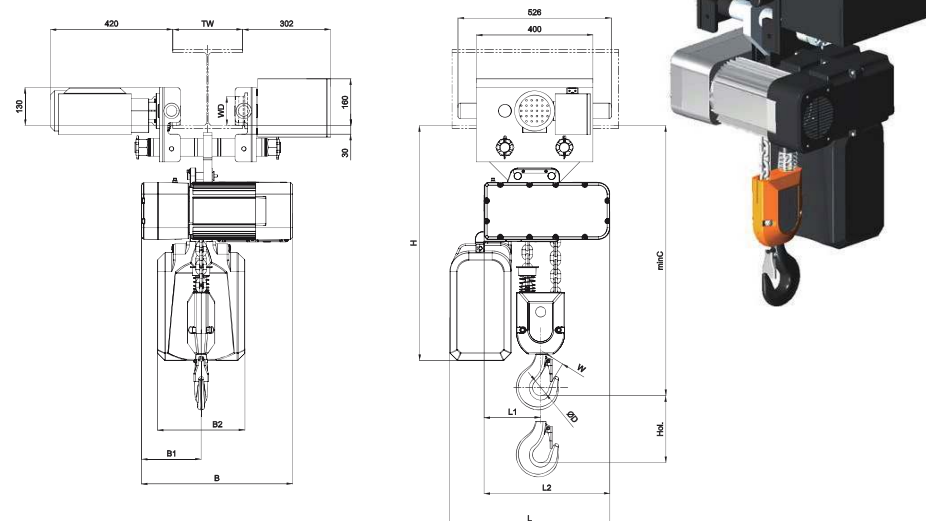

Product Dimensions and Parameters

size (mm)	Rated Load Capacity		Relevant Parameter	
	2000kg			
B	381.5		Lifting Motor Power kw	1.9/0.45
B1	184			
B2	195		Lifting Motor RPM r/min	2860/740
TW	70-300			
L	526		Trolley Motor Power kw	0.4
L1	152			
L2	413		Trolley Motor RPM r/min	1400
H	Hol ≤ 4m	608		
	Hol ≤ 8m	758	Trolley Speed m/min	5-20
WD	82			
W	40		Protection Class	IP54
D	50			
C	690		Insulation Class	F
Applicable Model for Overall Dimensions	NCH2072 16004M/E NCH2072 20004M/E			
			100+(Hol-3)*2.16	

Product Dimensions and Parameters

size (mm)	Rated Load Capacity		Relevant Parameter	
	3200kg	5000kg		
B	519		Lifting Motor Power kw	3.5/0.86
B1	205			
B2	300		Lifting Motor RPM r/min	2860/740
TW	80-300			
L	549		Trolley Motor Power kw	0.64
L1	322	311.5		
L2	432		Trolley Motor RPM r/min	2410
H	Hol ≤ 8m	/		
	Hol ≤ 6m	733	Trolley Speed m/min	5-20
WD	100			
W	40	45	Protection Class	IP54
D	50	56		
C	800	832	Insulation Class	F
Applicable Model for Overall Dimensions	NCH5092 25004M/E NCH5092 32004M/E			
			191+(Hol-3)*3.54	
			5000kg: Total Weight/kg	
			198+(Hol-3)*5.62	